



Cobar Europe BV
 PO Box 3251
 4800 DG Breda

Tel +31 (0) 76 544 55 66
 Fax +31 (0) 76 544 55 77
 Internet <http://www.cobar.com>

EC Date..... : 20 Sep 06
 Release..... : 06.1

User's Guidelines Cobar solder flux 385-X

Supporting Documents

See the Product Data Sheet (PDS) for the specification of the product concerned. An up to date version of the PDS for most current products is available through our website at www.cobar.com. Should the PDS of this product not be available through the website, please contact us by e-mail at info@cobar.com. See the Material Safety Data Sheet (MSDS) before handling and/or using this product.

Receiving

Do not leave shipments outdoors. Try to avoid prolonged exposure of the containers to heat, frost or rain. Solder materials are perishable. They should be treated accordingly.

Storage, Handling, Shelf-life

The shelf-life of Cobar solder fluxes is best guaranteed at temperatures below 20 °C and a relative humidity below 70%. However, for those circumstances where the temperatures (temporarily) may rise beyond the conditions as mentioned, we have designed a table to estimate the shelf-life.

Storage Temperatures/Shelf-life

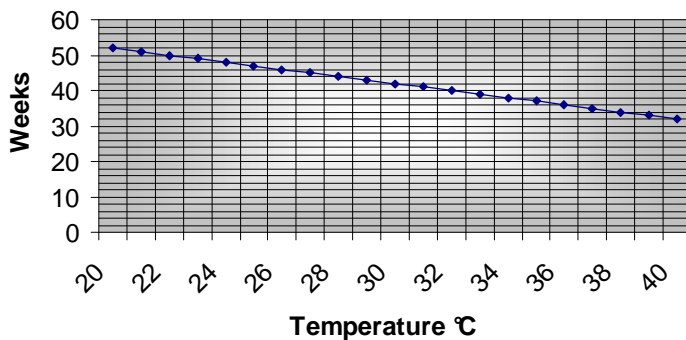

We, however, would like to emphasize that this is a general recommendation, as it does not include the influence of humidity and sunlight.

An air-conditioned room usually is adequate for storage.

Solder materials are shelf-life items and should be managed as a FIFO-supply.

Older batches should be used prior to new batches. The batch age can be identified by the expiry date on the label on the packaging.

Restoring flux after frost

In general, it is recommended to store flux that has been exposed to frost, for a minimum of 4 hours in a room in the proximity of a central heating system and to shake the cans several times before the flux is used.

Home | Company | Products | Service & Supply | Technical info

Certificate of Compliance

Product: **390-RX**
 General Wave Solder Fluxes

Batch Number: 17090
 Product date: 19-09-06
 Release: 2.0

Sample: 0.2 Ltr
 Quality Assurance by: Jir Groessen
 Number of samples: 1
 Approved by: Ivan Tiggelen

We hereby certify that the above mentioned product has been duly quality controlled in our laboratories, according to the procedures and instructions as set forth in our ISO/TS 16949 Quality Management System, KEMA certificate number 2076548, IATF number 0043973, and that the aforementioned product meets the specifications as stated below:

Test	Description	Unit	Spec	Tolerance
001	Specific gravity (20°)	K/D/M ³	0.813	-0.002 / +0.002
002	Acid number	mg/KOH	15.32	-0.393 / +0.393
005	Weight loss R ₂ O	% w/w	1.95	-5% / +5%
015	Ver Abs. Cl/Br	AgCl ₅	no change	-none / +none

This document has been generated automatically upon a pass-word protected command by an authorized staff-member. Therefore it is considered official without a signature.

Cobar Europe BV

< Back | Print certificate

Certificate of Compliance

A Certificate of Compliance (COC) certifies all batches produced by Cobar. The COC on every batch can be obtained through our website at www.cobar.com (Quality Certified).

This document confirms that the product has been duly quality controlled in our laboratories, according to the procedures and instructions as set forth in our ISO/TS 16949 Quality Management System, KEMA certificate number 2076548, IATF number 0043973.

For more details and procedures, please contact Cobar.

User's Guidelines Cobar solder flux 385-X

2/11

Statistical Process Control (SPC)

As a part of Cobar's Quality System, the QC-results of every batch are logged into our Statistical Process Control System (SPC). Under certain conditions the SPC-data can be audited by our customers.

Bare boards, Solder resist & Solder balling

Our product in general has shown good compatibility with most currently available solder resists, ranging from wet resists to dry-films. So far, no attack of the resist surface or any other type of incompatibility could be detected. More important, however, is the process history of the bare board. Therefore it is recommended to specify an ionic contamination, prior to the assembly of the bare board, of max. 0.5 micrograms/cm².

When proper disciplines are taken into account with regard to the manufacturing, storage and handling of the bare board, this flux appears to contribute to the elimination of solder balling.

Should you require some assistance in improving your process in this respect, please contact our application experts at www.cobar.com (Who is Cobar → Who is Who).

Pallets, Carriers, Fingers and other support items

Strips of board material at the side of breakaway panels will prevent any edge contamination.

The non-metallic parts of pallets and other support items should be of a high-temperature resistant quality. Prolonged use of inferior material in the high-temperature environment of the soldering equipment usually results in surface degradation and delamination. The latter will finally result in entrapment of flux solvents that may erupt violently when the assembly is exposed to the heat of the solder in wave.

Chips, fingers, pallets and other support items prevent the contact between some areas on the circuit board and the solder wave. In those cases where these support items have a relatively large square surface this might lead to some edge contamination on the circuit board. Therefore, the square surface of these items should be kept to a minimum.

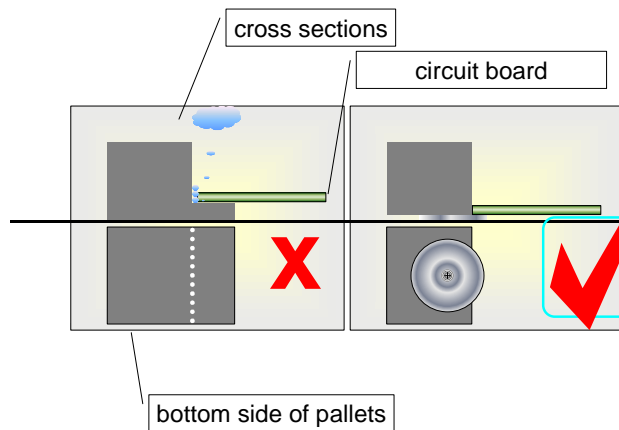

So-called shadow effects should be avoided during the application of the flux, as well as during the contact with the solder wave. This can be achieved by minimizing the difference in height between the bottom surface of the pallet or other support items and the surface on the solder side of the circuit board. Shadow effects also might cause turbulence in the solder wave and therefore are a potential cause for defects such as solder balling and bridging. Fingers, pallets, carriers and other support items should be cleaned and maintained on a regular basis in order to maintain good soldering results and clean circuit boards.

Setting of the Conveyor system

The angle of the conveyor system should be set at min. 5°, 7° nominal and 9° max.

The initial setting of the conveyor speed depends on the beat-rate of the assembly line, the topside preheat temperature and the contact time with the solder wave. In general, conveyor speeds of 100 to 150 cm (3 to 5 feet) per minute are possible with this product on boards of relatively good solderability.



Cobar Europe BV
PO Box 3251
4800 DG Breda

Tel +31 (0) 76 544 55 66
Fax +31 (0) 76 544 55 77
Internet <http://www.cobar.com>

EC Date..... : 20 Sep 06
Release..... : 06.1

User's Guidelines Cobar solder flux 385-X

3/11

Flux application temperature

The recommended ambient conditions for application of the product are 18-25 °C.

There are many types of fluxing systems and a large spectrum of possible process conditions. Therefore the following recommendations should be considered as guidelines for the initial setting of the process.

Clean everything before you start!

Clean the flux tank, spray- or foam-nozzle, foam-stone, rotating drum, density controller, fingers, pallets or carriers with the recommended thinner (see Product Data Sheet). **Don't forget to wash the tubes** (connection between the container or density controller and fluxing unit).

This product is a colorless and clear material. If you start up a machine and the flux becomes yellow, it means that the fluxing unit was not clean enough and that you have to dispose the flux because it has been contaminated by the product that has been used before, or by other sorts of contamination. This contamination may result in contact problems and residues.

Air supply

The use of pneumatic air is preferred over a membrane pump. The pneumatic air must meet following requirements:

1. Dry
2. Free from oil
3. Controlled temperature

A water and oil separator prior to supplying the air to the fluxing unit is strictly necessary. Eventually a silica gel filter or a freeze-dryer may be added. Especially in hot areas of the world, sometimes cooling the air is required to maintain a good foam-head in the case of foam-fluxing.

Advantages of spray-fluxing

Generally spray-fluxing is the preferred application for obtaining the best results:

1. Less residue; most accurate control of flux layer thickness on the assembly (1.0 to 2.0 microns).
2. Less flux consumption (longer lifetime).
3. Less or no thinner consumption.
4. Better process control of the flux.
5. No flux drippings over the preheat-zone.

Spray-fluxing

1. Set the spray width and length as accurately as possible.
2. should be set around 10-20% higher, compared with the setting for alcohol based fluxes.
3. Allow the nozzle to spray in open air and look closely at the visual spray appearance. A stable and uniform spray-cone should be visible, with the finest possible droplets, at the lowest possible settings of the pneumatic air pressure. When the pressure is set too low, the flux-droplets get bigger and unstable and ultimately the spray cone may collapse. Excessive high settings, however, may cause a bouncing effect of the flux against the board surface. Excessively high pressure spray nozzle settings may rather cause a bouncing effect than an improvement of the wetting of the board surface. High settings will only lead to more contaminated boards and equipment and an a waste of flux. In fact bouncing flux may even result in accumulation of air underneath the PCB, preventing a proper penetration in the thru-holes.
4. Turn the board upside down and evaluate the spray-pattern. It is essential that a continuous, uniform spray pattern has been deposited all across the paper. In the case that (dry) stripes or spots are visible, while other areas have been wetted, apply more flux (in small increments) for the next test. Should the problem persist, start experimenting with other combinations of transport speed, fluxer-

movement speed, fluxer pitch and airpressure. Take your time to adjust the spray performance properly. Carry out the experiments in a systematic way. Record every change in parameter settings. Never change more than 1 parameter at the time! Finally you will arrive at a combination of the aforementioned parameters that results in a perfect spray pattern, provided the spray fluxer has been designed properly.

- The minimum flux amount setting is the one that provides a continuous and uniform, but barely wet pattern on the paper. The maximum setting provides a copiously wetted, but just not dripping piece of paper. Evidently, In between the minimum and maximum settings is your fluxer process window. The better your fluxer design, the larger the window. A setting in the middle of this window can be considered as the ideal initial setting.
- After having arrived at the optimum setting for air pressure, the spray performance should be tested. Wrap a piece of (thermal) paper around the solderside of one of your largest (bare) boards. Tape it to the board on its topside so that the paper stays flat on the solderside. Use a new piece of paper for every test. Run the board passed the fluxer-unit. Take it out immediately after it has been fluxed.

Foam-fluxing

- Start up with a new foam stone preferably with 3 and maximum 10 micron pores. In any case make sure the foam stone is a high-density stone and it has been scrupulously cleaned in the recommended thinner.
- Fill up the fluxing unit to the maximum level. This is the level at which the foam won't run over the edge of the flux tank.
- Use pneumatic air of a quality as specified under the heading **Air Supply** in this document.
- Start up with minimum air pressure and slowly increase the pressure until a stable foam-head with a fine bubble structure is achieved.
- There are many types of fluxing systems. Therefore it is not possible to be more specific with our recommendations regarding pressure and flow-volume of the compressed air.
- Adjusting the proper contact between the foam-head and the surface of the circuit board over the fluxing-unit must be done by means of the height-adjustment screws of the fluxing unit. Don't change the air-pressure for this purpose! An adequate contact between the foam-head and the surface of the circuit board usually should not exceed 2 cm (0.75").
- Avoid flooding of the flux across the topside of the circuit board. This would result in unnecessary residues on the topside of the circuit board.

Foam-fluxer design and Foam stone

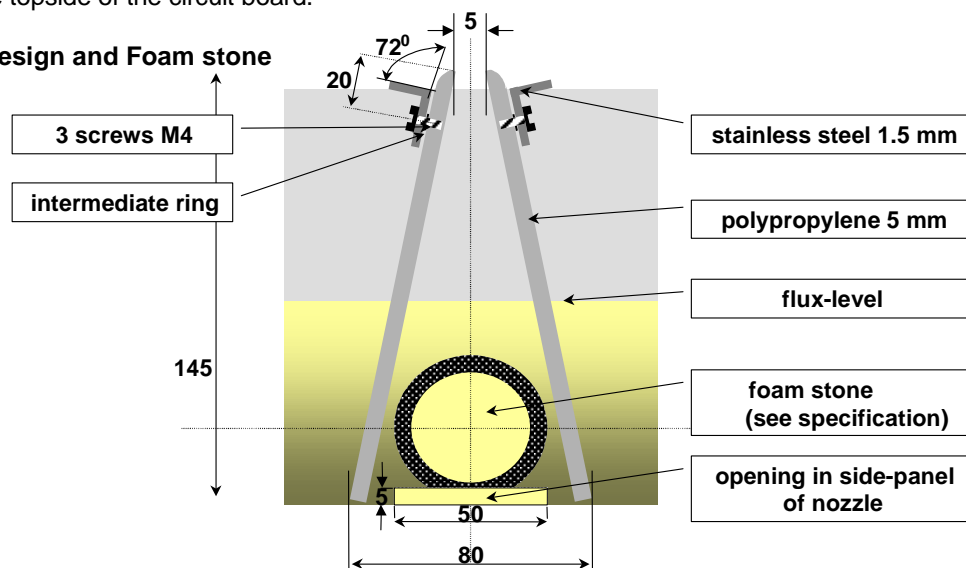



Cobar Europe BV
PO Box 3251
4800 DG Breda

Tel +31 (0) 76 544 55 66
Fax +31 (0) 76 544 55 77
Internet <http://www.cobar.com>

EC Date..... : 20 Sep 06
Release..... : 06.1

User's Guidelines Cobar solder flux 385-X

5/11

A foam stone supplied by Pall Schumacher GmbH (Shumatherm and Filhoplast 3 μ) provides a stable and extremely fine foam-head.

Company:

Pall Schumacher GmbH
Zur Flügellau 70
74564 Crailheim
Postfach 1562
74555 Crailsheim
Germany

Tel. : +49 79 51 30 20
Telefax : +49 79 51 26 598
E-mail : susi.buckel@europe.pal.com
Website : www.schumacher-filters.de

Setting the air-knife

An air-knife following the foam-fluxing unit is strongly recommended to reduce the amount of flux applied by the foam fluxer. This controls the amount of residues on the assembly after soldering but also prevents flux drippings over the preheat zone.

1. The ideal blow-angle of the air-knife is 10 degrees, reverse to the transport direction of the boards.
2. The distance between the air-knife and the foam-nozzle must be minimum 10 cm (4") to avoid blowing in the foam head. The distance of the air-knife to the board: ± 5 cm (2").
3. The air pressure must be adjusted in such a way that the flux drops are removed without pushing them through the holes on topside of the board.
4. The ideal air-knife has a tube diameter of 10 mm, a hole diameter of ± 1.0 mm and the axial distance of the holes is 5.0 mm.
5. Ideally the air-knife/foam fluxer combination should be set in a way that the excessive flux is blown back onto the inclined dripping plate of the fluxing-unit.

The Preheat profile

Following preheat profile should be considered as a recommendation for an initial. It ensures a smooth and complete evaporation of the solvents and optimum activation of the flux. This will provide the best wetting results and minimizes, yet fully inerted residues for high-reliability applications.

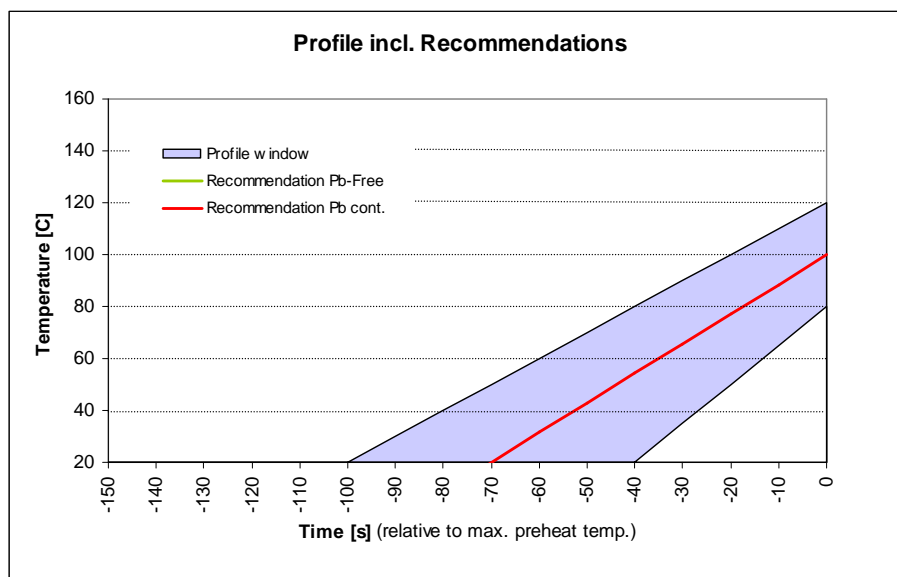



Cobar Europe BV
PO Box 3251
4800 DG Breda

Tel +31 (0) 76 544 55 66
Fax +31 (0) 76 544 55 77
Internet <http://www.cobar.com>

EC Date.....: 20 Sep 06
Release.....: 06.1

User's Guidelines Cobar solder flux 385-X

6/11

The fitness of any profile should be carefully evaluated in each application with regard to cosmetic appearance, in-circuit testing and circuit reliability. Within the context of a quality management system it is recommended to calibrate the profile on a regular basis and log the measuring results of temperature monitoring systems into an SPC-system.

Delta T

In order to optimize the Delta T between preheat and solder temperature one can raise the preheat temperature as high as indicated in the profile.

Wave settings

Even if no SMT components are used at the solder side of the assembly, the use of a chip wave may assist in minimizing the amount of residue after soldering. The initial wave temperature is 250 °C (482 °F). In order to compensate for an adequate Delta T between the preheat profile and the wave temperature you can set the wave temperature as low as 235 °C (435 °F). For multi-layer boards you can set it as high as 260 °C (500 °F).

Setting up the solder wave(s)

The use of a thermal resistant glass plate with a line graduation of 10 mm (0.4") is recommended. With the glass plate you can set the initial wave pressure and the contact time. The wave pressure should be set so that the wave height is at 1/3 of the board thickness.

A simple test to check the coplanarity of the wave

Pass a fluxed and preheated glass plate through the wave. In the areas where you see white spots, no wave contact has taken place. If the plate is completely clean, the coplanarity of the wave contact is OK.

Chip wave

Set the pressure of the chip wave at a maximum pressure towards the underside of the assembly but just so that solder will not run over the topside. In order to maintain sufficient activity of the flux at the exit zone of the second wave, the contact time in the chip wave should not be much longer than approx. 1 second.

Other wave types

In case a wave profile is used exclusively with a counter-flow of the solder relative to the transport direction of the assembly, the oxides may become entrapped between the assembly and the wave surface. They eventually will stay on the assembly. The oxides will accumulate as the assembly progresses in the wave and have their impact on the surface tension and the flow properties of the solder, ultimately resulting in bridging, icling and webbing.

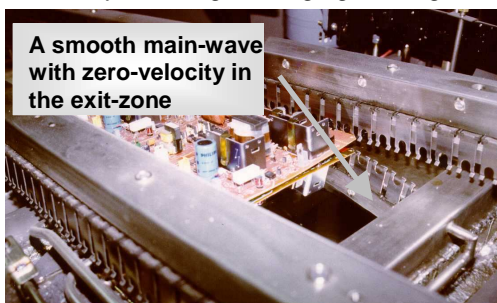

When the solder wave is provided with a back plate, the latter should be set so that solder will only flow over the back plate when a circuit board touches the surface of the wave. This will result in a flow speed of the solder, which is equal to the transport speed of the assembly. This often is referred to as the zero-velocity condition. It provides a perfectly balanced wave which is able to eliminate defects related to turbulence in the liquid solder such as bridging, icling and solder balls. We recommend you to set this condition with the aforementioned glass plate.

Bring the glass plate over the wave. When the glass plate touches the wave surface, the oxides on the surface will start to flow. When you stop the glass plate on the wave then the oxides must stop flowing.

User's Guidelines Cobar solder flux 385-X

7/11

Contact time

In order to obtain clean and well-soldered assemblies, a contact time in the solder wave of between 2.5 to 4 seconds is recommended. The contact time is also temperature dependent. When soldering at 250 °C (482 °F) a contact time of approximately 2.5 seconds is the recommended initial setting. When soldering at 235 °C (455 °F) a contact time of approximately 3.5 seconds is the recommended initial setting.

Flux control

In open fluxing units this product will lose some solvent due to evaporation. Restoring the solvent-ratio by hand in one-hour intervals is possible but certainly not ideal. Therefore, continuous process control with an automatic density controller is strongly recommended, backed up with a manual titration procedure for Acid Number of the flux once per day or two days.

Reading values for SG and Acid Number

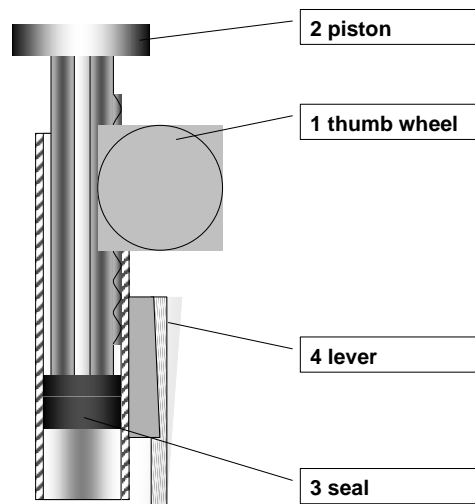
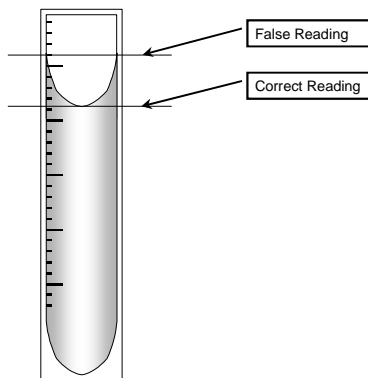

Determination of acid number

CAUTION: This test procedure has been developed exclusively for this particular product and cannot be used for other products. **All glassware needs to be scrupulously clean** in order to achieve reliable and reproducible results.

Required chemicals/materials

1. Phenolphthalein (1.0 %)
2. 0.1 N KOH solution
3. Isopropyl alcohol (99.9)
4. Distilled water*
5. Lint-free tissue*

* not in test kit

Required tools/equipment

- 1 x dispensing bottle with graduated 50 ml cup
- 1 x pipette pump (max. capacity 25 ml)
- 2 x Erlenmeyer flask 100 ml
- 1 x measuring pipette 5 ml
- 1 x measuring pipette 20 ml
- 1 x medicine dropper
- watch, timer or stop-watch*
- 1 x 250 ml bottle



Cobar Europe BV
 PO Box 3251
 4800 DG Breda

Tel +31 (0) 76 544 55 66
 Fax +31 (0) 76 544 55 77
 Internet <http://www.cobar.com>

EC Date.....: 20 Sep 06
 Release.....: 06.1

User's Guidelines Cobar solder flux 385-X

8/11

Preparation

The dispensing bottle has to be filled with isopropyl alcohol.
 The medicine dropper has to be filled with the phenolphthalein solution.
 The 250 ml bottle has to be filled with the 0.1 N KOH solution.

Procedure

1. Fill the cup on the dispensing bottle with 30 ml. isopropyl alcohol exactly by squeezing the bottle gently. Pour the alcohol into the Erlenmeyer flask.
2. Add 2 drops (but no more!) of phenolphthalein with the medicine dropper.
3. Insert the 5 ml measuring pipette into the chuck of the pump with a slight pressure. This assures a secure fit.
4. Push the piston (illustration, pos. 2) all the way down to its starting position at the pump housing.
5. Draw a sample of the flux by turning the thumb-wheel of the pipette pump (illustration, pos. 1) so the piston moves upwards. At the same time you will see the flux level rise in the pipette. The pipette should be filled completely.
6. Adjust the volume in the pipette by carefully pressing the lever (illustration, pos. 4) on the pipette pump until the 0.00 ml point has been reached exactly.
7. In the case the 0.00 ml has been surpassed, repeat step 6 of this procedure.
8. Add 5.00 ml into the Erlenmeyer by holding the pipette and Erlenmeyer in an angle of 45°.
9. Dismount the pipette pump from the 5 ml pipette. To loosen the pipette pull slightly.
10. Insert the 20 ml measuring pipette into the chuck of the pump with a slight pressure. This assures a secure fit.
11. Push the piston (illustration, pos. 2) all the way down to its starting position at the pump housing.
12. Draw up the KOH solution by turning the wheel of the pipette pump. The pipette should be filled completely.
13. Adjust the volume in the pipette by carefully pressing the lever (illustration, pos. 4) on the pipette pump until the 0.00 ml point has been reached exactly.
14. In the case the 0.00 ml point has been surpassed, repeat step 13 of this procedure.
15. Swing the Erlenmeyer gently in one hand while holding the pipette pump in the other hand with the lower end of the pipette in the Erlenmeyer.
16. By pressing the lever (4) on the pipette pump, titrate the KOH-solution carefully into the Erlenmeyer. A faint pink color change will occur every now and then, but it will disappear within seconds after some swinging of the Erlenmeyer. When it takes longer for the pink color to disappear one should be **extremely careful when pressing the lever (4)** on the pipette pump. After every addition thorough swinging of the Erlenmeyer should be practiced all the time.
17. When the time span between the appearance and the disappearance of the faint pink color increases a timer should be kept stand-by to monitor the number of seconds.
18. Continue titration until a faint pink color persists for 15 seconds. **However, don't exceed the 15 seconds color change!**
19. Read the used ml (V1) from the pipette.
20. Perform a determination in duplicate (V2).

Calculation	
$\frac{V1 + V2}{2} = \text{Acid Number} = V \times 1,361893 = \dots\dots\dots \text{mg KOH/gr. Sample}$	



Cobar Europe BV
 PO Box 3251
 4800 DG Breda

Tel +31 (0) 76 544 55 66
 Fax +31 (0) 76 544 55 77
 Internet <http://www.cobar.com>

EC Date.....: 20 Sep 06
 Release.....: 06.1

User's Guidelines Cobar solder flux 385-X

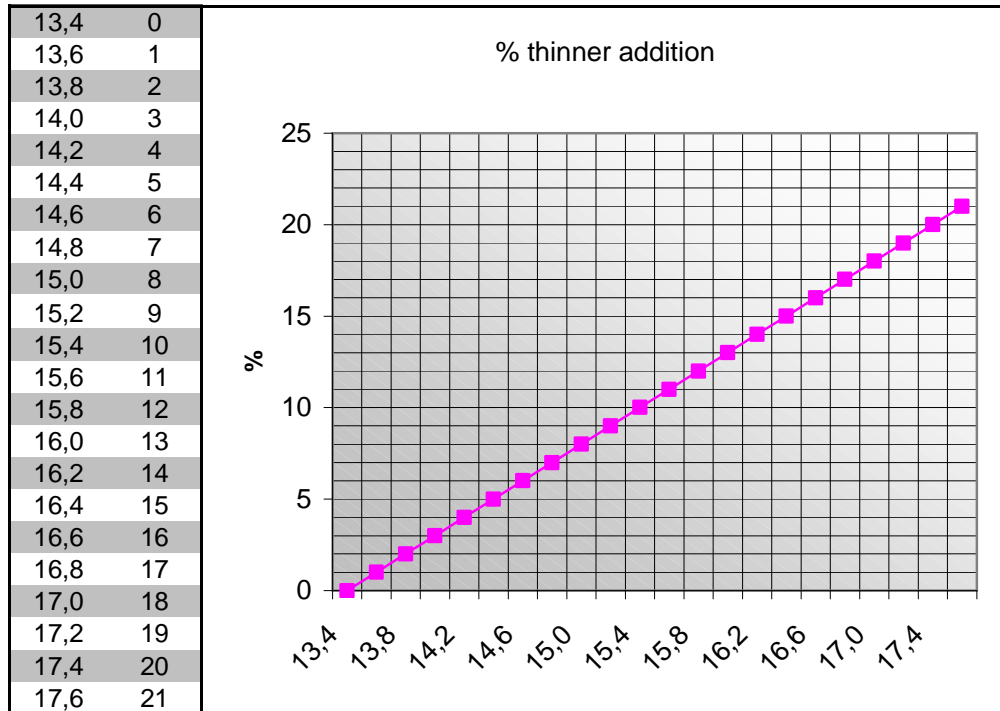

Calculation of the manual adjustment of Specific Gravity of the flux

Flux	385-X	SG	liters	equation
A	Measurement of Specific Gravity at 20°C	0,828		
B	Actual quantity of flux in fluxing-unit		36,0	
C	Specified Specific Gravity at 20°C Type of thinner 425-00	0,824		
D	Specific Gravity of thinner at 20°C	0,786		
E	Quantity of thinner to add		3,8	$((A-C)*1000)/((C-D)*1000)*B$
F	Total quantity obtained after dilution with thinner		39,8	$B+E$
G	Maximum quantity of flux in fluxing unit		40,0	

If the thinner-addition causes the total quantity to exceed the capacity of the fluxer:

Take some flux out according to following calculation and replace it by thinner

	liters	equation
H	Quantity of flux to take out	-0,19 $((A-C)*1000)/((A-D)*1000)*G-(G-B)$
I	Quantity of thinner to add	3,81 $((A-C)*1000)/((A-D)*1000)*G$

Entering the equations in a spread-sheet program such as Microsoft Excel facilitates this routine.
 On your request we can also send you a copy.



Cobar Europe BV
 PO Box 3251
 4800 DG Breda

Tel +31 (0) 76 544 55 66
 Fax +31 (0) 76 544 55 77
 Internet <http://www.cobar.com>

EC Date.....: 20 Sep 06
 Release.....: 06.1

User's Guidelines Cobar solder flux 385-X

10/11

**Temperature compensation of Specific Gravity
 Flux 385-X**

°C	Specific Gravity (Kg/DM3)													
1	0,833	0,834	0,835	0,836	0,837	0,838	0,839	0,840	0,841	0,842	0,843	0,844	0,845	0,846
2	0,833	0,834	0,835	0,836	0,837	0,838	0,839	0,840	0,841	0,842	0,843	0,844	0,845	0,846
3	0,832	0,833	0,834	0,835	0,836	0,837	0,838	0,839	0,840	0,841	0,842	0,843	0,844	0,845
4	0,831	0,832	0,833	0,834	0,835	0,836	0,837	0,838	0,839	0,840	0,841	0,842	0,843	0,844
5	0,830	0,831	0,832	0,833	0,834	0,835	0,836	0,837	0,838	0,839	0,840	0,841	0,842	0,843
6	0,830	0,831	0,832	0,833	0,834	0,835	0,836	0,837	0,838	0,839	0,840	0,841	0,842	0,843
7	0,829	0,830	0,831	0,832	0,833	0,834	0,835	0,836	0,837	0,838	0,839	0,840	0,841	0,842
8	0,828	0,829	0,830	0,831	0,832	0,833	0,834	0,835	0,836	0,837	0,838	0,839	0,840	0,841
9	0,827	0,828	0,829	0,830	0,831	0,832	0,833	0,834	0,835	0,836	0,837	0,838	0,839	0,840
10	0,827	0,828	0,829	0,830	0,831	0,832	0,833	0,834	0,835	0,836	0,837	0,838	0,839	0,840
11	0,826	0,827	0,828	0,829	0,830	0,831	0,832	0,833	0,834	0,835	0,836	0,837	0,838	0,839
12	0,825	0,826	0,827	0,828	0,829	0,830	0,831	0,832	0,833	0,834	0,835	0,836	0,837	0,838
13	0,824	0,825	0,826	0,827	0,828	0,829	0,830	0,831	0,832	0,833	0,834	0,835	0,836	0,837
14	0,824	0,825	0,826	0,827	0,828	0,829	0,830	0,831	0,832	0,833	0,834	0,835	0,836	0,837
15	0,823	0,824	0,825	0,826	0,827	0,828	0,829	0,830	0,831	0,832	0,833	0,834	0,835	0,836
16	0,822	0,823	0,824	0,825	0,826	0,827	0,828	0,829	0,830	0,831	0,832	0,833	0,834	0,835
17	0,821	0,822	0,823	0,824	0,825	0,826	0,827	0,828	0,829	0,830	0,831	0,832	0,833	0,834
18	0,821	0,822	0,823	0,824	0,825	0,826	0,827	0,828	0,829	0,830	0,831	0,832	0,833	0,834
19	0,820	0,821	0,822	0,823	0,824	0,825	0,826	0,827	0,828	0,829	0,830	0,831	0,832	0,833
20	0,819	0,820	0,821	0,822	0,823	0,824	0,825	0,826	0,827	0,828	0,829	0,830	0,831	0,832
21	0,818	0,819	0,820	0,821	0,822	0,823	0,824	0,825	0,826	0,827	0,828	0,829	0,830	0,831
22	0,818	0,819	0,820	0,821	0,822	0,823	0,824	0,825	0,826	0,827	0,828	0,829	0,830	0,831
23	0,817	0,818	0,819	0,820	0,821	0,822	0,823	0,824	0,825	0,826	0,827	0,828	0,829	0,830
24	0,816	0,817	0,818	0,819	0,820	0,821	0,822	0,823	0,824	0,825	0,826	0,827	0,828	0,829
25	0,815	0,816	0,817	0,818	0,819	0,820	0,821	0,822	0,823	0,824	0,825	0,826	0,827	0,828
26	0,815	0,816	0,817	0,818	0,819	0,820	0,821	0,822	0,823	0,824	0,825	0,826	0,827	0,828
27	0,814	0,815	0,816	0,817	0,818	0,819	0,820	0,821	0,822	0,823	0,824	0,825	0,826	0,827
28	0,813	0,814	0,815	0,816	0,817	0,818	0,819	0,820	0,821	0,822	0,823	0,824	0,825	0,826
29	0,812	0,813	0,814	0,815	0,816	0,817	0,818	0,819	0,820	0,821	0,822	0,823	0,824	0,825
30	0,812	0,813	0,814	0,815	0,816	0,817	0,818	0,819	0,820	0,821	0,822	0,823	0,824	0,825
31	0,811	0,812	0,813	0,814	0,815	0,816	0,817	0,818	0,819	0,820	0,821	0,822	0,823	0,824
32	0,810	0,811	0,812	0,813	0,814	0,815	0,816	0,817	0,818	0,819	0,820	0,821	0,822	0,823
33	0,809	0,810	0,811	0,812	0,813	0,814	0,815	0,816	0,817	0,818	0,819	0,820	0,821	0,822
34	0,809	0,810	0,811	0,812	0,813	0,814	0,815	0,816	0,817	0,818	0,819	0,820	0,821	0,822
35	0,808	0,809	0,810	0,811	0,812	0,813	0,814	0,815	0,816	0,817	0,818	0,819	0,820	0,821
36	0,807	0,808	0,809	0,810	0,811	0,812	0,813	0,814	0,815	0,816	0,817	0,818	0,819	0,820
37	0,806	0,807	0,808	0,809	0,810	0,811	0,812	0,813	0,814	0,815	0,816	0,817	0,818	0,819
38	0,805	0,806	0,807	0,808	0,809	0,810	0,811	0,812	0,813	0,814	0,815	0,816	0,817	0,818
39	0,805	0,806	0,807	0,808	0,809	0,810	0,811	0,812	0,813	0,814	0,815	0,816	0,817	0,818
40	0,804	0,805	0,806	0,807	0,808	0,809	0,810	0,811	0,812	0,813	0,814	0,815	0,816	0,817



Cobar Europe BV
PO Box 3251
4800 DG Breda

Tel +31 (0) 76 544 55 66
Fax +31 (0) 76 544 55 77
Internet <http://www.cobar.com>

EC Date..... : 20 Sep 06
Release..... : 06.1

User's Guidelines Cobar solder flux 385-X

11/11

Flux residues

When applied in a proper way, no visible residue can be detected with the human eye. No sticky residues at all. So far practically no test failures have been reported on ICCT due to flux residue. Cleaning - if necessary at all - could be carried out successfully with products like 3% detergent Cobar 608 in water. Tools and equipment can also be cleaned in this way.

Conformal coatings

When properly processed, this flux is compatible with many conformal coatings based on acrylic, polyurethane and silicon resins.

Chemical resistance of equipment to flux materials and their condensates

Solder materials contain solvents that dissolve rosins and synthetic resins. The solvents must have the solvency power to maintain a stable product. Their potential to dissolve even synthetic resins make it necessary to check the compatibility of non-metallic parts in soldering equipment with the flux and its condensates. In general the use of PVC and Viton parts, wires and cables should be avoided at all times. Non-metallic materials with good resistance are Polyethylene, Polypropylene, Nylon and Teflon. Two pack coatings and primers generally are resistant. 316-L has proven to be a compatible stainless steel.